

# SAVAGE CRANE HIRE

"Lifting your business to new heights"

## Dimensions

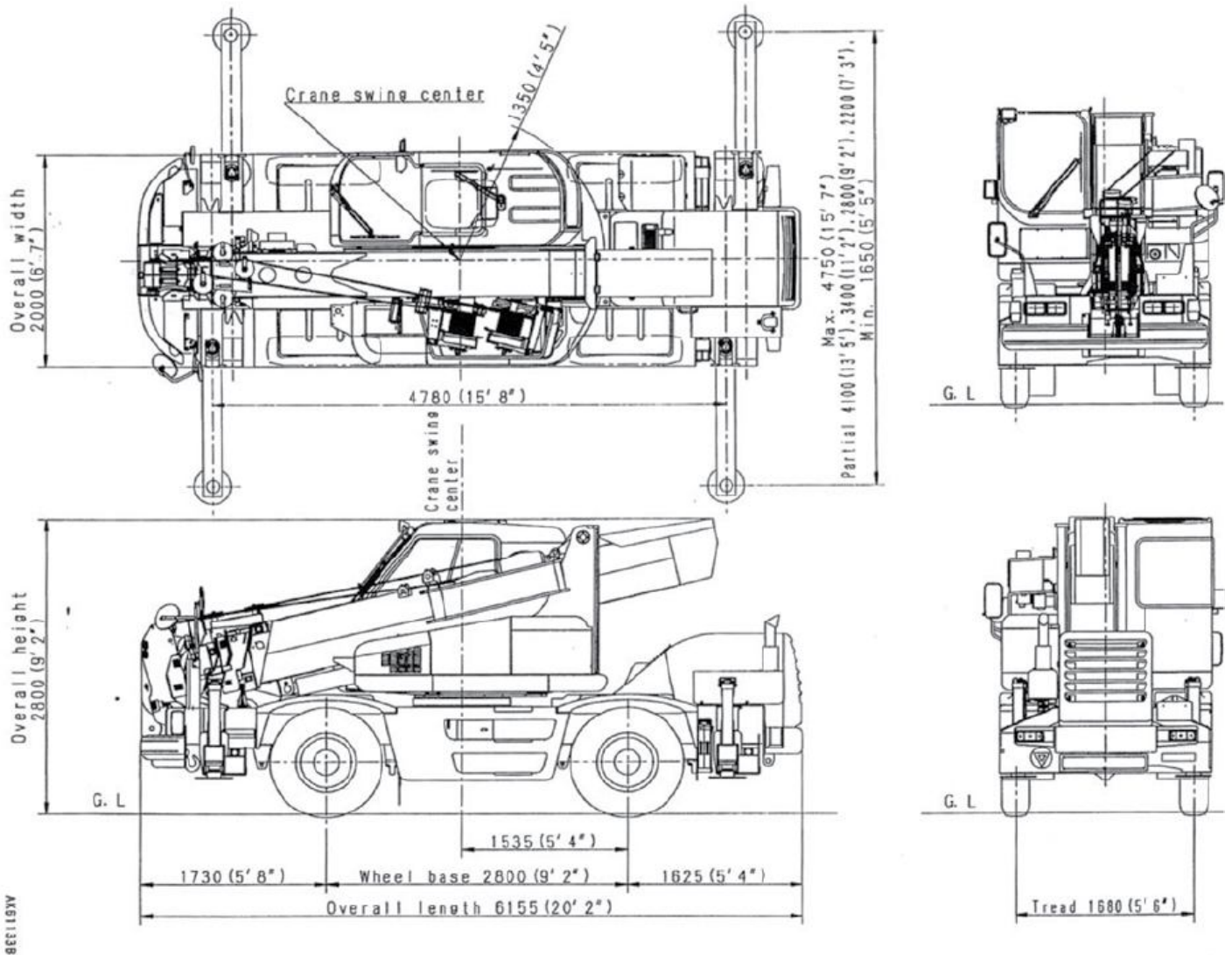

~ Contact KANE 0438 768 224 ~

Email: [sales@savage.com.au](mailto:sales@savage.com.au) Web: [www.savage.com.au](http://www.savage.com.au)

# SAVAGE CRANE HIRE

**"Lifting your business to new heights"**

## Specifications

[Machines equipped with H-shaped outrigger]

PERFORMANCE			
	Boom length	Capacity	Conditions
● Crane capacity	4.1 m (13 ft 5 in)	10 t x 2.5 m (8 ft 2 in) (10 t hook specification) 4.9 t x 3.0 m (9 ft 10 in) (4.9 t hook specification)	Outrigger fully extended, 360° operations
	7.6 m (24 ft 11 in)	5.0 t x 4.0 m (13 ft 1 in) (10 t hook specification) 4.9 t x 4.0 m (13 ft 1 in) (4.9 t hook specification)	
	11.1 m (36 ft 5 in)	5.0 t x 4.0 m (13 ft 1 in) (10 t hook specification) 4.9 t x 4.0 m (13 ft 1 in) (4.9 t hook specification)	
	14.5 m (45 ft 17 in)	4.0 t x 4.5 m (14 ft 9 in) (10 t hook specification) 4.0 t x 4.5 m (14 ft 9 in) (4.9 t hook specification)	
	18.0 m (59 ft 1 in)	4.0 t x 4.0 m (13 ft 1 in) (10 t hook specification) 4.0 t x 4.0 m (13 ft 1 in) (4.9 t hook specification)	
	21.5 m (70 ft 6 in)	2.0 t x 6.0 m (19 ft 8 in) (10 t hook specification) 2.0 t x 6.0 m (19 ft 8 in) (4.9 t hook specification)	
	7.6 m (24 ft 11 in)	1.0 t x 5.0 m (16 ft 5 in)	
	11.1 m (36 ft 5 in)	4.05 t x 1.5 m (4 ft 11 in)	With suspension lock, outriggers not used, over-front operations
	4.1 m (13 ft 5 in)	3.4 t x 1.0 m (3 ft 3 in)	With suspension lock, outriggers not used, 360° operations
	● Main winch line speed (high-low) 5 levels	117 – 62 m (383 ft 10 in – 203 ft 5 in)/min	
● Auxiliary winch line speed (high-low) 4 levels	108 – 57 m (354 ft 4 in – 187 ft)/min		
● Time taken to raise boom (-13° – 83°)	31 sec		
● Time taken to extend boom (4.1 m – 21.5 m (13 ft 5 in – 70 ft 6 in))	59 sec		
● Travel speed	0 – 49 km/h (0 – 30 MPH)		
● Min. turning radius	2-wheel steering	7.11 m (23 ft 4 in)	
	4-wheel steering	3.95 m (13 ft)	
WEIGHT			
● Operating weight (not including operator)	12,750 kg (28,114 lb)		
BOOM			
● Boom length/(boom + jib length)	4.1 m – 21.5 m (13 ft 5 in – 70 ft 6 in)		
● Wire rope dimensions	Main winch	Ø 10 mm x 120 m (Ø 0.4 in x 393 ft 8 in)	
	Auxiliary winch	Ø 10 mm x 56 m (Ø 0.4 in x 183 ft 9 in)	
● Type of rope	IWRC 6 X WS36 C type, normal Z lay		
ENGINE			
● Type	Komatsu S6D96L-1 diesel engine		
● Rated horsepower	110 kW (148 HP) / 3000 rpm		
● Max. torque	435 N·m (44.4 kgf·m, 321.1 lbf·ft) / 1,800 rpm		
● Starting motor	24 V 4.5 kW		
● Alternator	24 V 50 A		
● Battery	12 V 95E41R Ah x 2 pieces		
TIRE			
● Size	Standard	11R22.5 – 16PR Steel radial tubeless	
	If equipped	275/80R22.5 Steel radial tubeless	
		315/80R22.5 Steel radial tubeless *	

If equipped suspension lock

# SAVAGE CRANE HIRE

"Lifting your business to new heights"

## Rated Overall Load Table

Boom operations with outriggers set

Outriggers fully extended 4.75m (360°) X.H type

(Unit: ton)

Working radius (m)	Boom length					
	4.1 m	7.6 m	11.1 m	14.5 m	18.0 m	21.5 m
1.0	10.00 (4.90)	5.00 (4.90)				
1.5	10.00 (4.90)	5.00 (4.90)	5.00 (4.90)			
2.0	10.00 (4.90)	5.00 (4.90)	5.00 (4.90)	4.00		
2.5	10.00 (4.90)	5.00 (4.90)	5.00 (4.90)	4.00	4.00	
3.0	8.00 (4.90)	5.00 (4.90)	5.00 (4.90)	4.00	4.00	2.00
3.5		5.00 (4.90)	5.00 (4.90)	4.00	4.00	2.00
4.0		5.00 (4.90)	5.00 (4.90)	4.00	4.00	2.00
4.5		4.60	4.40	4.00	3.60	2.00
5.0		4.20	3.90	3.55	3.20	2.00
5.5		3.80	3.50	3.20	2.90	2.00
6.0		3.40	3.15	2.90	2.70	2.00
6.5		3.10 (6.4 m)	2.90	2.70	2.50	1.90
7.0			2.65	2.50	2.30	1.80
8.0			2.25	2.10	1.95	1.60
9.0			1.90	1.80	1.70	1.45
10.0			1.58 (9.9 m)	1.55	1.50	1.30
11.0				1.35	1.33	1.20
12.0				1.15	1.14	1.10
13.0				1.00	1.00	1.00
14.0				0.92 (13.4 m)	0.90	0.86
15.0					0.77	0.76
16.0					0.65	0.67
17.0					0.56 (16.8 m)	0.58
18.0						0.50
19.0						0.42
20.0						0.35
21.0						0.33 (20.3 m)
Danger angle	—	—	—	—	—	—

# SAVAGE CRANE HIRE

**"Lifting your business to new heights"**

## Working Radius / Lifting Height Chart

The chart below shows the relationship between the operating radius and lifting height when the outriggers are fully extended.

The value given does not include the deflection of the boom.

This diagram shows the values to be applied when the outriggers are extended to the maximum (360°).

